

### FEATURES

- Half port and single port designs for maximum layout flexibility
- Low profile packages from 2.39 mm to 1.98 mm for PC Card and Cardbus applications
- Compatible with Intel, TDK, QSI, and ICS transceivers
- Isolation Voltage : 1500 Vrms

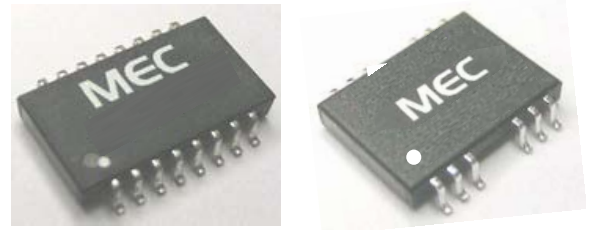

Part Number	Turns Ratio Pri:Sec(± 3%)		Insertion Loss (dB MAX)	Return Loss (dB TYP)			Crosstalk (dB TYP)			Differential to Common Mode Rejection (dB TYP)			Common to common Rejection Ratio (dB TYP)
	TX	RX		30 MHz	60 MHz	80 MHz	30 MHz	60 MHz	100 MHz	30 MHz	60 MHz	100 MHz	
S31722NL	1:1	1:1	-1.20	-18	-12	-11	-45	-40	-35	-40	-35	-30	-30
S31741NL	1:1	1:1	-1.20	-16	-12	-10	-50	-45	-40	-35	-33	-20	-30
S31765NL	1:1	1:1	-1.10	-16	-12	-11	-45	-40	-35	-35	-30	-20	-30
S31766NL	1:1	1:1	-1.00	-18	-15	-12	-40	-38	-33	-35	-30	-20	-33
S31778NL	1:1	1:1	-2.00	-18	-14	-12	-50	-45	-40	-40	-35	-30	-30
S31787NL	1.41:1	1:1	-1.10	-16	-12	-10	-45	-40	-30	-35	-30	-25	-30

● Electrical Specifications @25°C-Operating Temperature 0°C to 70°C.

### Mechanicals

#### S31741NL

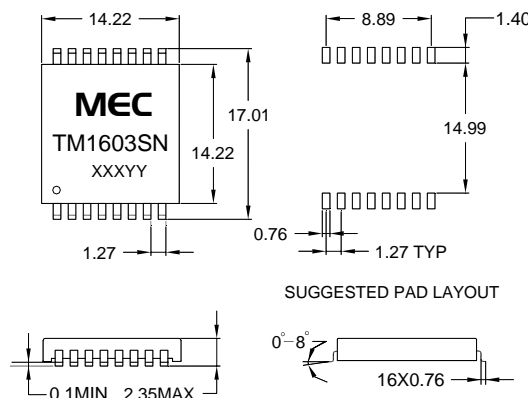

#### S31765NL, S31766NL, S31787NL

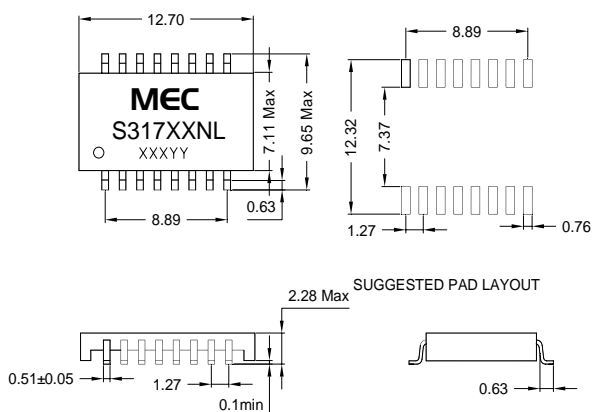

#### S31722NL, S31778NL

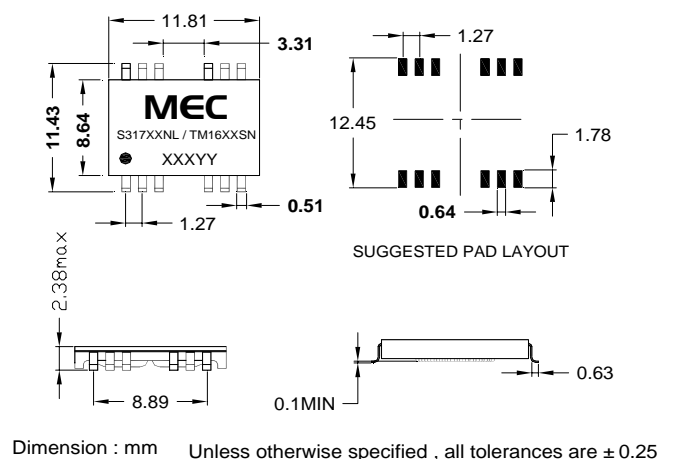

### Schematics

**S31722NL**

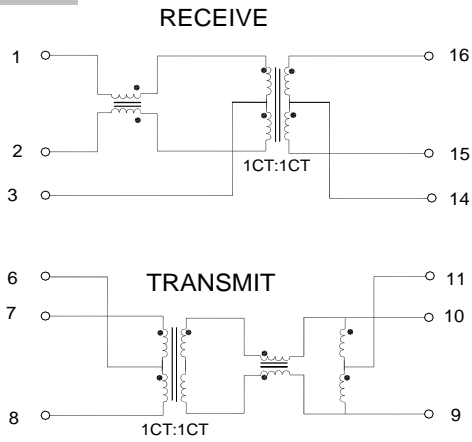

**S31741NL**

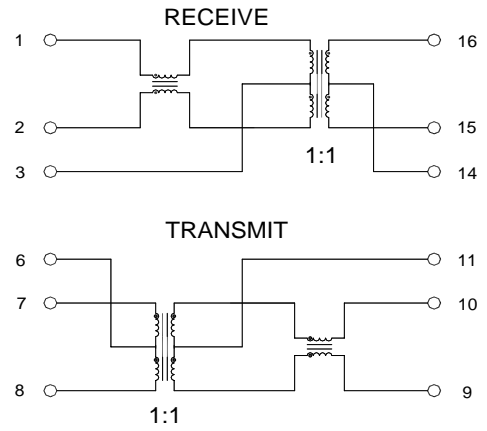

**S31765NL**

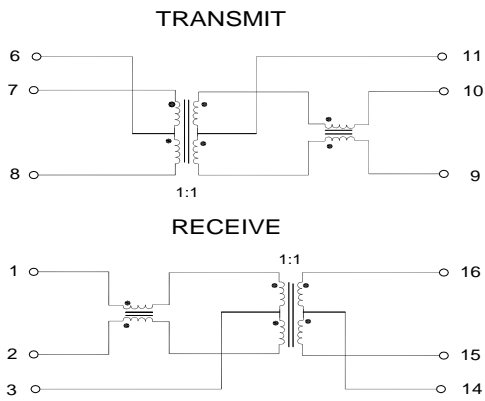

**S31766NL**

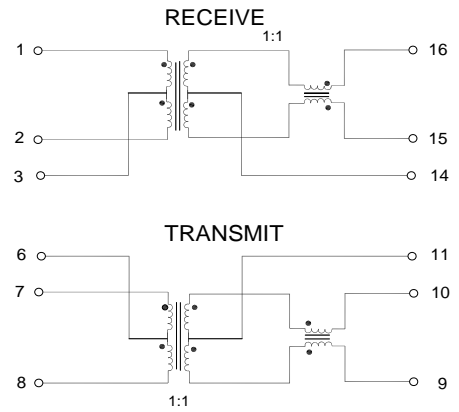

**S31778NL**

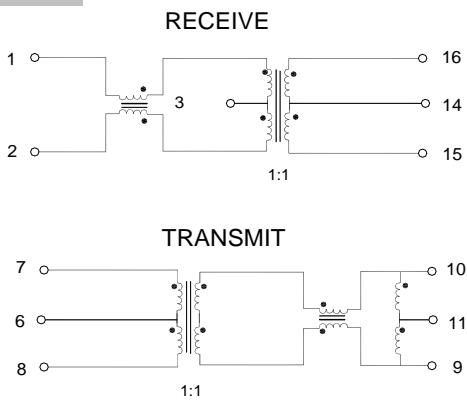

**S31787NL**

