

### FEATURES

- Meets IEEE 802.3 and ANSI X3.263 standards, Including 350 uH OCL with 8 mA bias
- Symmetrical TX and RX channels for auto MDI/MDIX capability
- Designed for reflow soldering at temperatures Up to 255-265°C
- Isolation Voltage : 1500 Vrms

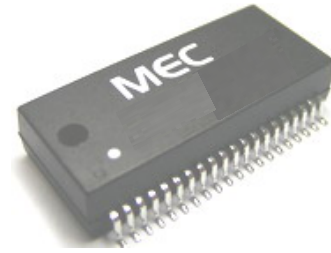

Part Number	Turns Ratio Pri:Sec(± 3%)		Insertion Loss (dB MAX)	Return Loss (dB TYP)			Crosstalk (dB TYP)			Differential to Common Mode Rejection (dB TYP)			Common to common Rejection Ratio (dB TYP)
	TX	RX		0.1~100 MHz	30 MHz	60 MHz	80 MHz	30 MHz	60 MHz	100 MHz	30 MHz	50 MHz	
S34103N	1:1	1:1	-1.1	-18	-14	-11	-40	-33	-30	-40	-35	-30	-25
S34105N	1:1	1:1	-1.2	-16	-12	-10	-38	-33	-30	-40	-37	-28	-35
S34106N	1:1	1:1	-1.0	-17	-14	-10	-45	-40	-35	-40	-37	-30	TX -40 / RX -25
S34107N	1:1	1:1	-1.0	-17	-14	-10	-45	-40	-35	-40	-37	-30	TX -35 / RX -25
S34109N	2:1	1:1	-3.5	-18	-14	-12	-47	-42	-38	-40	-37	-30	-40
S34111N	1:1	1:1	-1.1	-16	-12	-10	-40	-35	-30	-40	-37	-30	-25
S34114N	1:1	1:1	-1.1	-18	-13	-12	-45	-40	-35	-42	-37	-30	-25
S34119N	1:1	1:1	-1.0	-16	-14	-10	-45	-40	-38	-45	-40	-30	-35
S34120N	1:1	1:1	-1.4	-16	-10	-10	-40	-35	-30	-45	-40	-30	-25
S34122N	2:1	1:1	-1.0	-18	-12	-10	-55	-45	-35	-45	-40	-30	-30
S34123N	1:1.414	1:1	-1.0	-18	-12	-10	-55	-45	-35	-45	-40	-30	-30
S34125N	1.25:1	1:1	-1.0	-18	-12	-10	-55	-45	-35	-45	-40	-30	-30
S34126N	2:1	1:1	-1.0	-18	-12	-10	-55	-45	-35	-42	-40	-30	-25
S34130N	1:1	1:1	-1.15	-16	-12	-10	-40	-35	-32	-40	-37	-28	-25
S34132N	1:1	1:1	-1.0	-16	-12	-10	-40	-33	-28	-40	-37	-30	-30
S34140N	1:1	1:1	-1.1	-16	-12	-10	-40	-35	-30	-40	-37	-30	-28
S34146NL	1:1	1:1	-1.1	-16	-12	-10	-40	-35	-30	-40	-37	-30	-25
S34148NL	1:1	1:1	-1	-18	-13	-12	-45	-40	-33	-40	-37	-30	-25

- Electrical Specifications @25°C-Operating Temperature 0°C to 70°C.

### Mechanicals

#### S341XXN

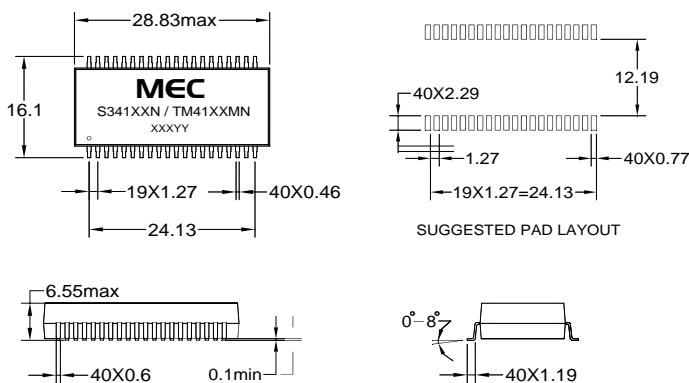

#### S34146NL / S34148NL

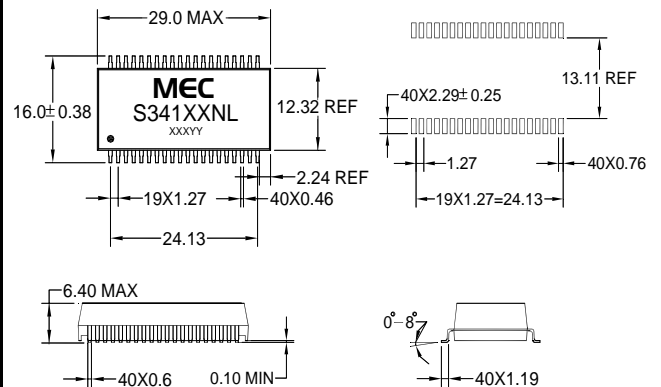

Dimensions:mm Unless otherwise specified,all tolerances are ± 0.25

Dimensions:mm Unless otherwise specified,all tolerances are ± 0.25

### Schematics

#### S34103N

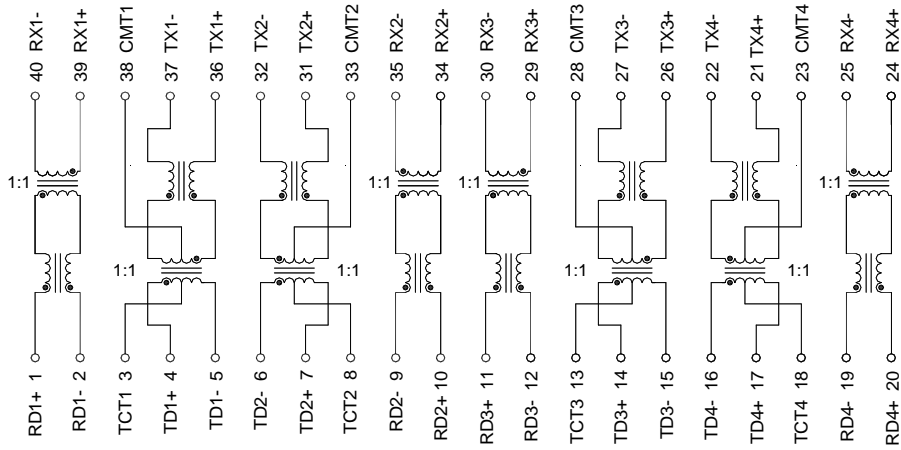

#### S34105N

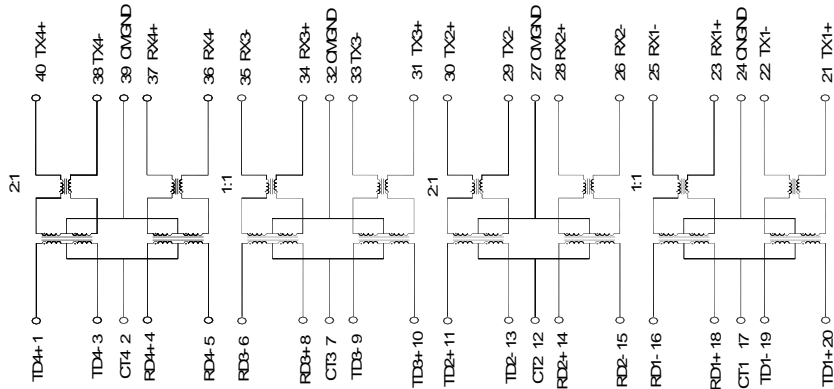

#### S34106N

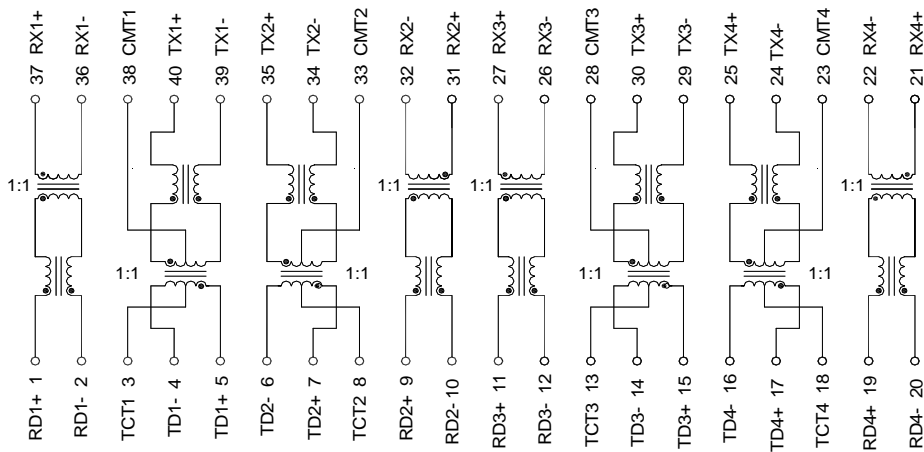

#### S34107N

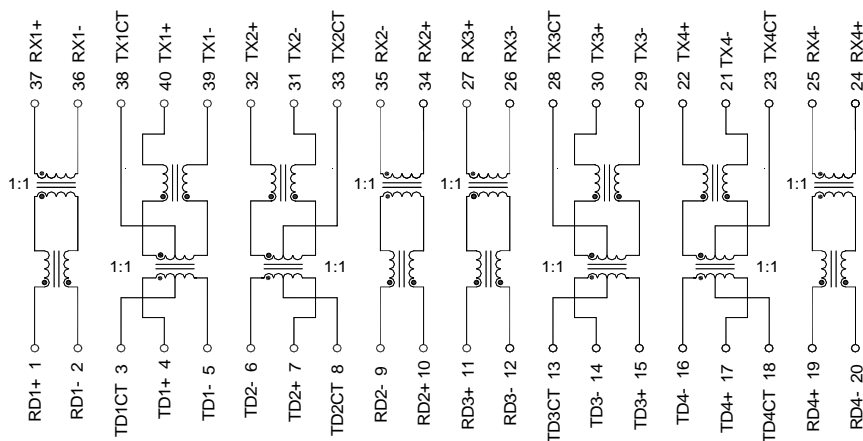

### Schematics

#### S34109N

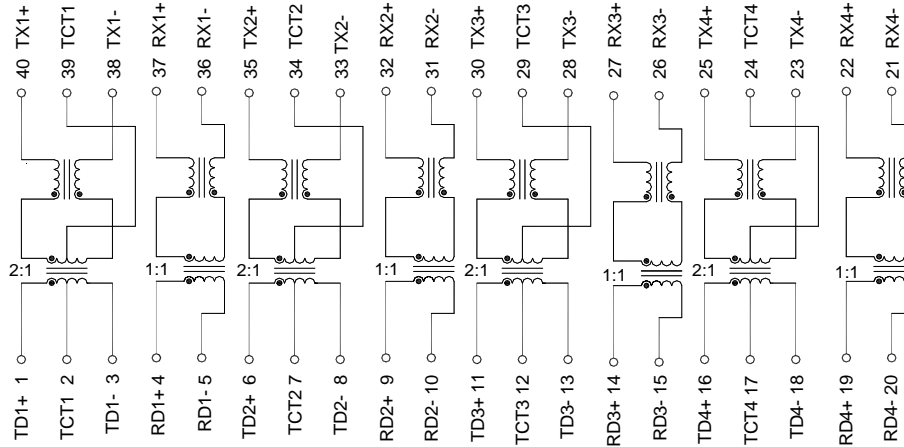

#### S34111N

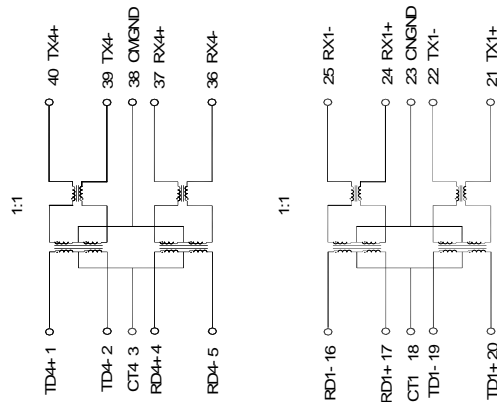

#### S34114N

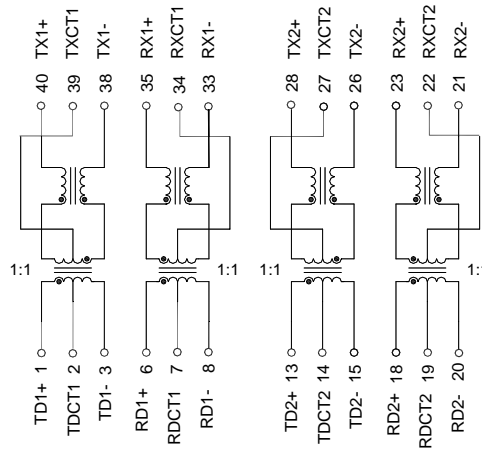

#### S34119N

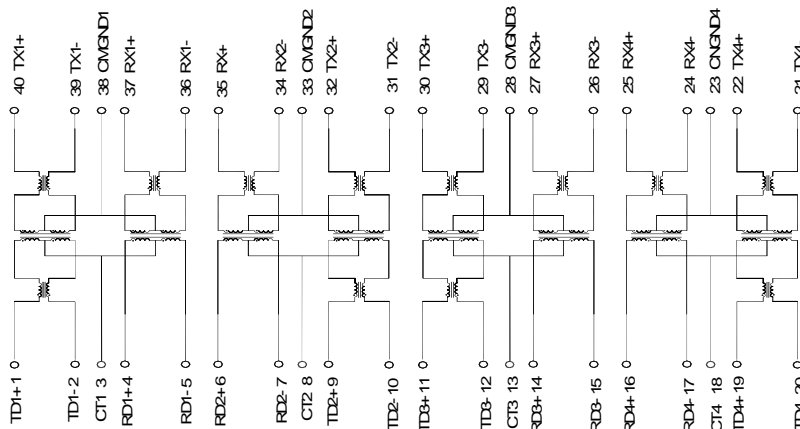

### Schematics

#### S34120N

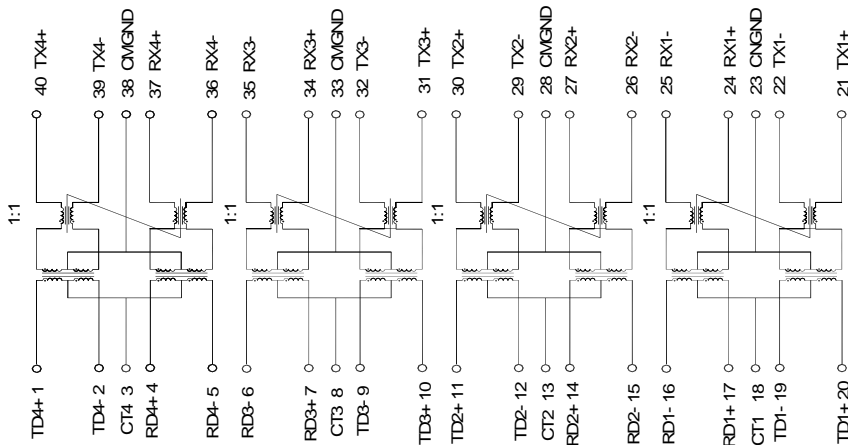

#### S34122N

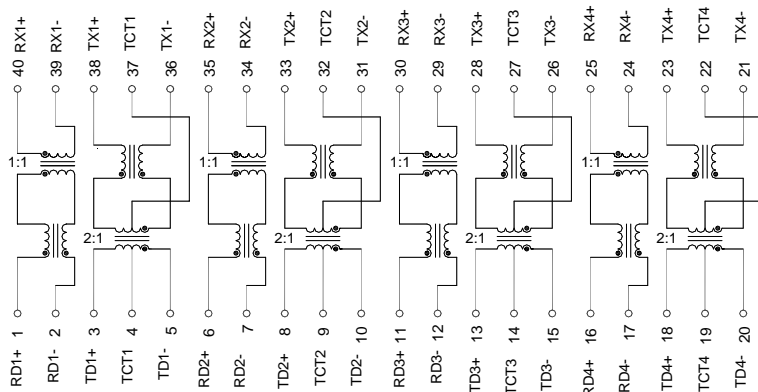

#### S34123N

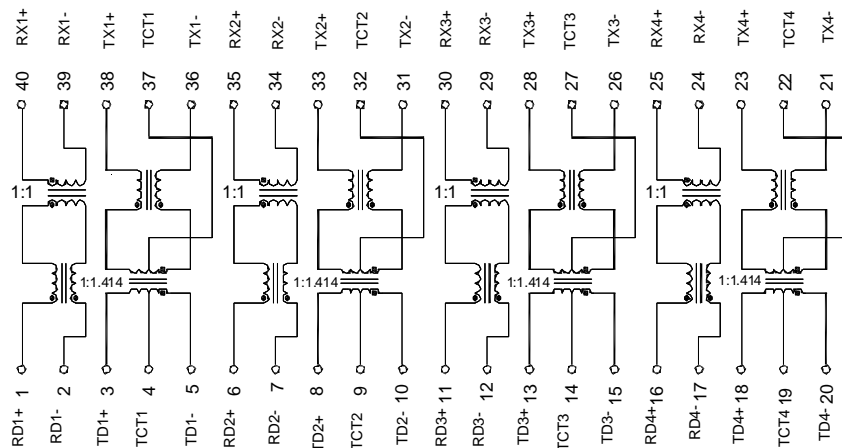

#### S34125N

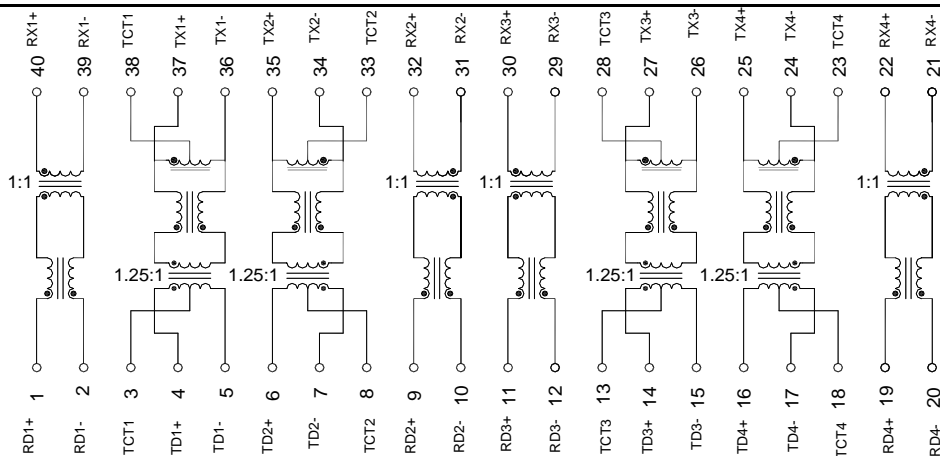

### Schematics

#### S34126N

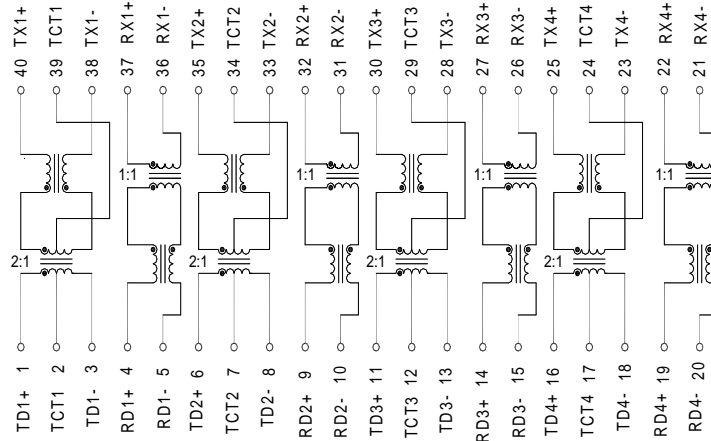

#### S34130N

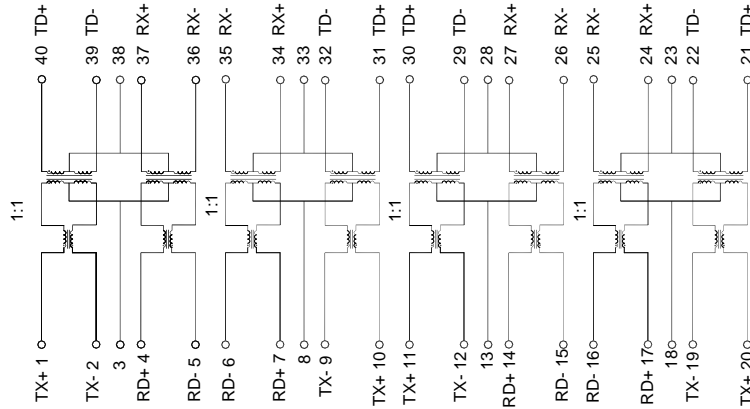

#### S34132N

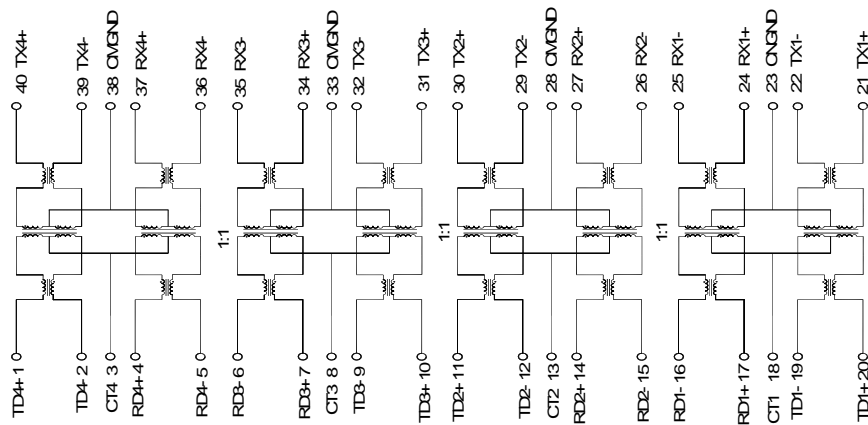

#### S34140N

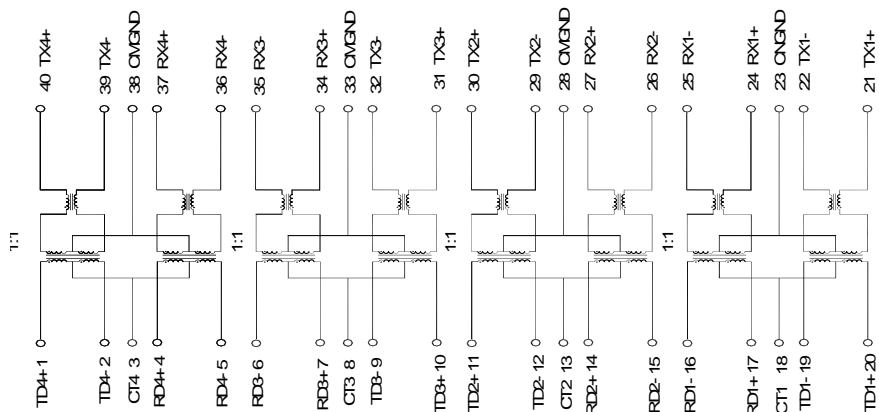

### Schematics

#### S34146NL

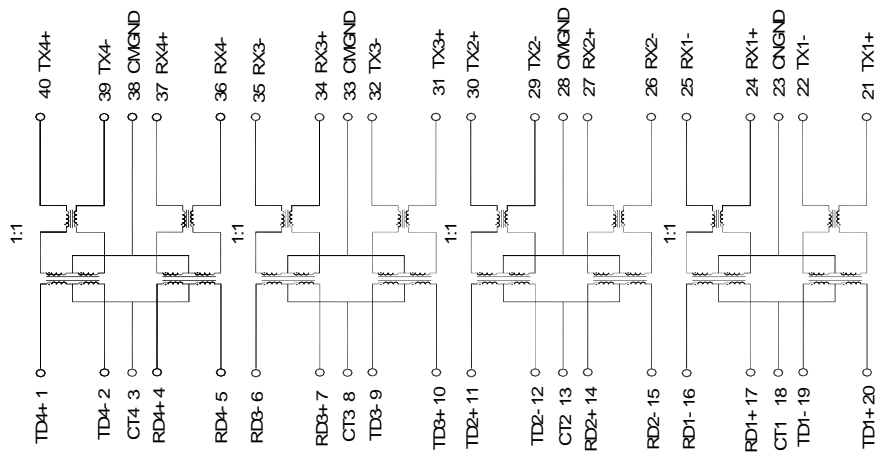

#### S34148NL

